

Crash Barrier

Objective

McCue products are tested for compliance and product failure analysis to determine safe working conditions.

Scope

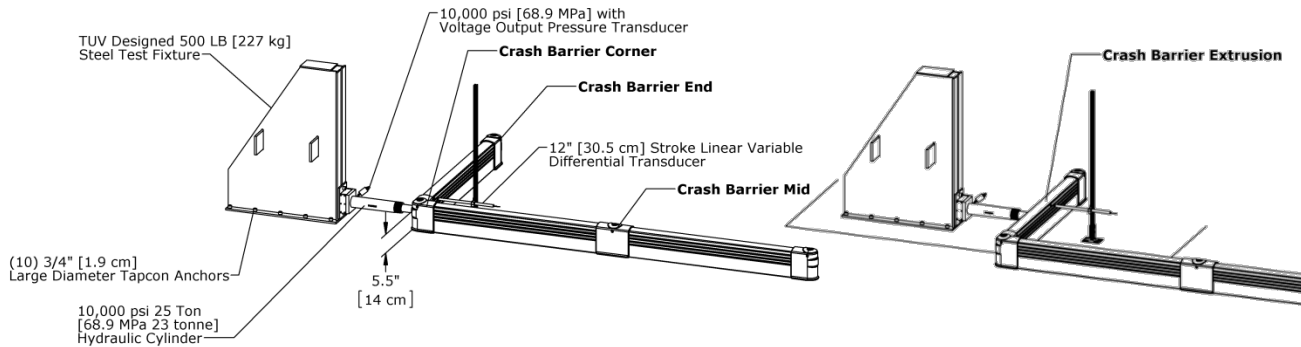

Products are tested for compliance to international standards and codes by taking dynamic measurements in real time of applied force and resulting deflection. These force and deflection measurements are used to determine the magnitude of energy transfer to the product by using the principles of the work energy theorem. The criteria for product failure has been defined as a 4" deflection with the intent of balancing product robustness, floor space, and application for safe working conditions. Failure occurs at fracture if fracture occurs at a deflection of less than 4" [10 cm].

Maximum Force & Deflection

Corner	End	Mid	Post End	Extrusion
$F_{max} = 22538 \text{ lb [100.3 kN]}$	$F_{max} = 25056 \text{ lb [111.5 kN]}$	$F_{max} = 11311 \text{ lb [50.3 kN]}$	$F_{max} = 13584 \text{ lb [60.4 kN]}$	$F_{max} = 1256 \text{ lb [5.6 kN]}$
$\delta_{max} = 3.9" [9.9 \text{ cm}]$	$\delta_{max} = 4.0" [10 \text{ cm}]$	$\delta_{max} = 3.9" [9.9 \text{ cm}]$	$\delta_{max} = 2.1" [5.3 \text{ cm}]$	$\delta_{max} = 4" [10 \text{ cm}]$
$v_i = 5.8 \text{ mph [9.3 km/h]}$	$v_i = 6.2 \text{ mph [10.1 km/h]}$	$v_i = 4.1 \text{ mph [6.5 km/h]}$	$v_i = 3.3 \text{ mph [5.4 km/h]}$	$v_i = 1.4 \text{ mph [2.2 km/h]}$
$v_{45} = 18.5 \text{ mph [41.7 km/h]}$	$v_{45} = 27.5 \text{ mph [44.3 km/h]}$	$v_{45} = 18.5 \text{ mph [29.8 km/h]}$	$v_{45} = 19.8 \text{ mph [32 km/h]}$	$v_{45} = 6.2 \text{ mph [10.1 km/h]}$

The lowest testing Crash Barrier rigid components can withstand point load of 11,311 lb [50.3 kN], equivalent to a 6,500 lb [2948 kg] vehicle at 4.1 mph [6.5 km/h]. The Crash Barrier extrusion can withstand an impact of 1256 lb [5.6 kN], equivalent to a 6,500 lb [2948 kg] vehicle at 1.4 mph [2.2 km/h] and recover to its original position.

The described test demonstrates the worst case scenario of a perpendicular impact. In application, typical impacts will be at an angle and result in lower collision energies. The Crash Barrier Mid can withstand a 45° angular impact from a 6,500 lb [2948 kg] vehicle traveling at $v_{45} = 18.5 \text{ mph [29.8 km/h]}$.

These tests were performed for McCue Corporation only and not subject to acceptance criteria. The test setup, testing, and measurement of data were all witnessed by TRIS and verified to have been performed in accordance with the specifications of BS 6399.